

POWER | *designer*

Expert tips, tricks, and techniques for powerful designs

No. 116

Feature Article.....1-7

LED Drivers for
1W/3W LEDs2

60V Low-Side MOSFET
Controller4

Switched Capacitor
Flash LED Driver.....6

Power Design Tools.....8

Driving LEDs: To Cap or Not to Cap

— By Chris Richardson, Applications Engineer

Introduction

High-brightness LEDs are available today with forward currents more than 100 times greater than their predecessors. These new devices are not just high brightness, but are high power as well. Single die with dissipations of 5W and multi-die modules with power in excess of 25W are now available. The requirements of high efficiency and low dissipation dictate a switching power supply for this new generation of High-Brightness (HB), High-Power (HP) LEDs, as a voltage regulator and a current limiting resistor are no longer appropriate. High-brightness, high-power LEDs require a constant-current source to take full advantage of their ever-increasing luminous efficiency and vibrant, pure color. The topology of choice for this new breed of switching constant current sources is the basic buck converter. The most convincing argument for using a buck converter is the ease with which this simple DC-DC converter can be turned into a constant-current source. This article will explain the selection of, or possible exclusion of, an output capacitor when designing a buck regulator for constant-current drive of HB LEDs.

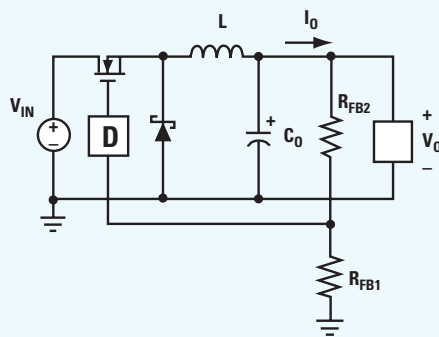

Figure 1a. Traditional Buck Voltage Regulator

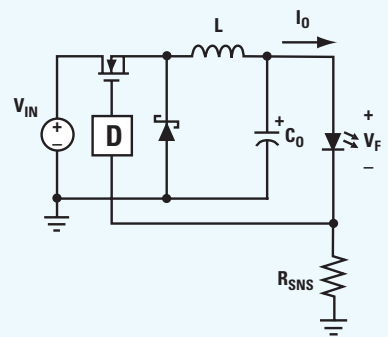

Figure 1b. Buck Current Regulator

NEXT ISSUE:
Design Challenges In Step-Down
Regulator Applications

 **National
Semiconductor**
The Sight & Sound of Information



New LED Drivers Power 1W/3W LEDs up to 1A

LM3402/04 Regulators Offer Low Current-Sense Voltage to Reduce Power Loss and Deliver High Efficiency up to 95%

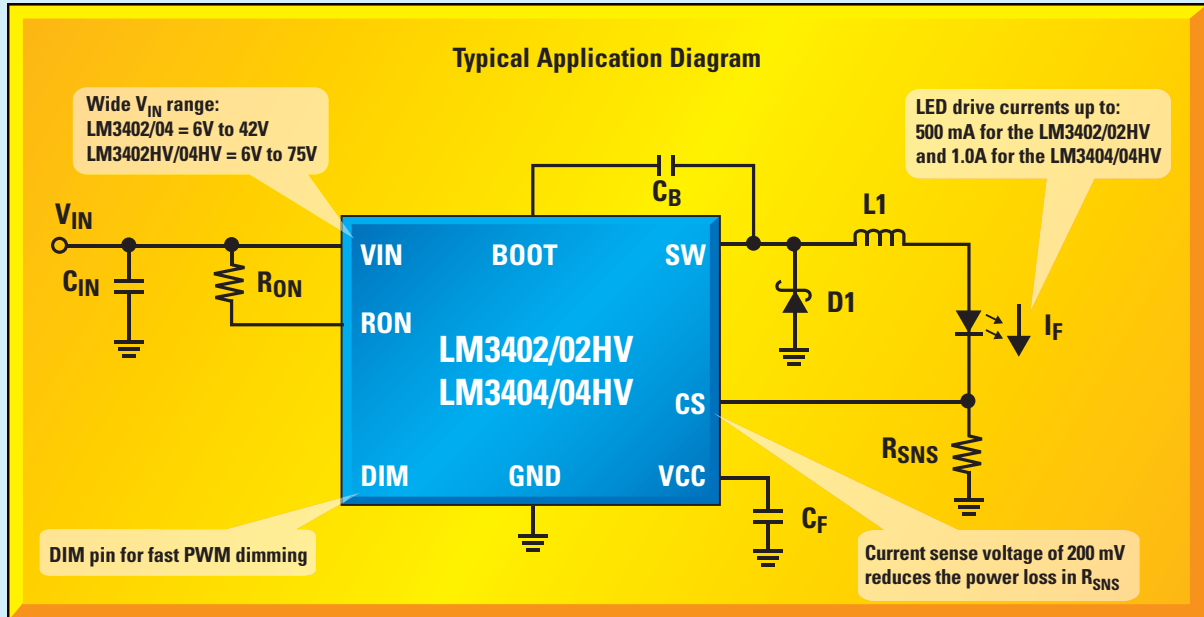

LM3402/04 Features

- Easy-to-use and low external parts count
- Switching frequency up to 1 MHz
- Constant on-time control with voltage feed-forward for nearly constant switching frequency over the full line voltage range
- Low 0.2V feedback reference minimizes power losses
- Low shutdown current when R_{ON} pin held low
- High voltage capability supports long strings of LEDs
- Choice of 0.5A or 1.0A peak current capability (LM3402/LM3404)

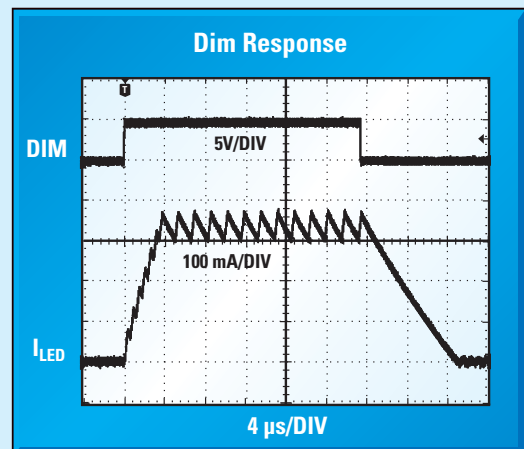

Ideal for use in automotive, industrial lighting, gaming/vending machines, general illumination, and architectural lighting applications

For **FREE** samples, datasheets, and more information, visit

www.national.com/pf/LM/LM3402.html

www.national.com/pf/LM/LM3404.html

Driving LEDs: To Cap or Not to Cap

Controlled Current

The buck regulator is uniquely suited to be a constant current driver because the output inductor is in series with the load. Regardless of whether a buck regulator is used as a voltage source or a current source, selection of the inductor forms the cornerstone of the system design. With an inductor in series with the output, the average inductor current is always equal to the average output current, and the buck converter naturally maintains control of the AC-current ripple. By definition, the LED drive is a constant load system; hence a large amount of output capacitance is not necessary to maintain V_O during load transients.

No Output Cap Yields High Output Impedance

In theory, a perfect current source has infinite output impedance, allowing the voltage to slew infinitely fast in order to maintain a constant current. For switching regulator designers who have concentrated on voltage regulators, this concept may take a moment to sink in. Completely removing the output capacitor from a buck regulator forces the output impedance to depend on the inductor. Without any capacitance to oppose changes in V_O , the output current (referred to as forward current, or I_F) slew rate depends entirely upon the inductance, the input voltage, and the output voltage. (V_O is equal to the combined forward voltage, V_F , of each series-connected LED)

LED manufacturers generally recommend a ripple current, ΔI_F , of $\pm 5\%$ to $\pm 20\%$ of the DC forward current. Over the typical switching regulator frequency range of 50 kHz to 2 MHz the ripple itself is not visible to the human eye. These limits come from increasing thermal losses at higher ripple current (a property of the LED semiconduc-

tor PN junction itself) and a practical limit to the inductance used. The percentages are similar to the recommended current ripple ratio in buck voltage regulators. Inductor selection for a fixed-frequency current regulator is therefore governed by the same equations as a voltage regulator:

$$L = \frac{V_{IN}}{V_F} \times \frac{V_{IN} - V_F}{\Delta i_L \times f_{SW}}$$

One difference is that the inductance used for current regulators without output capacitors tends to be higher because the drive currents for the emerging standards of 1W, 3W, and 5W HB LEDs are 350 mA, 700 mA, and 1A respectively. Modern buck voltage regulators tend to use inductors in the range of 0.1 μH to 10 μH with saturation currents from 5A to 50A. Current drivers at similar switching frequencies tend to require inductors ranging from 10 μH to 1000 μH and saturation currents ranging from 0.5A to 5A.

The main goal of high output impedance is to create a system capable of responding to PWM dimming signals, the preferred method of controlling the light output of LEDs. The dimming signal might be applied to the enable pin of the regulator, in which case the output current can slew from zero to the target and back to zero without the delay of C_O being charged and discharged. For even faster, higher resolution dimming, a shunt switch, usually a MOSFET, can be placed in parallel with the LED array, allowing the continuous flow of current at all times. Again, with no output capacitor to slow the slew rate, dimming frequencies into the 10's of kHz are possible. This is a critical requirement in applications such as backlighting of flat-panel displays, and the creation of white light using an RGB array.

High Voltage Current Mode Controller with Ultra-Wide Input Voltage Range

LM5022 with 6V to 60V Input Capability Controls an External MOSFET to Deliver Higher Current to LEDs

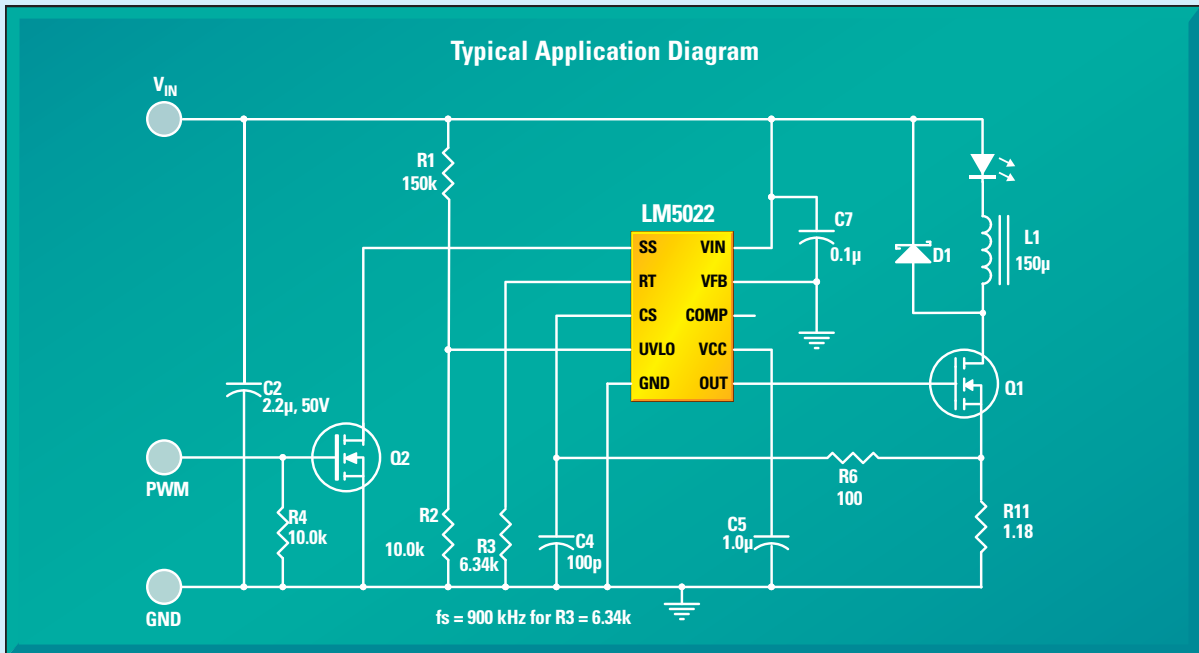

LM5022 Features

- Internal 60V startup regulator
- 1A peak N-Channel MOSFET gate driver
- V_{IN} range 6V to 60V
- Duty cycle limit in excess of 90%
- Programmable UVLO with hysteresis
- Cycle-by-cycle current limit
- Single resistor oscillator frequency set
- Slope compensation
- Adjustable soft-start
- Available in MSOP-10 packaging

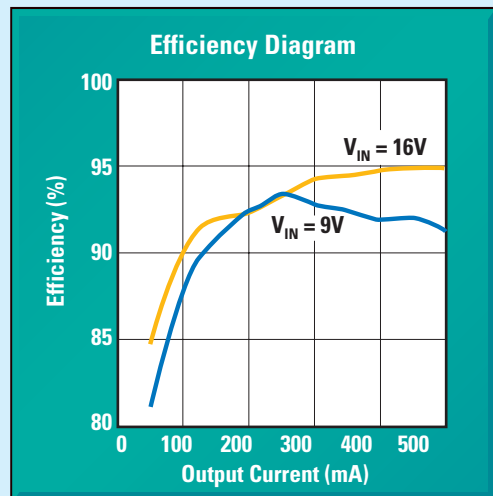

Ideal for use in boost and SEPIC converters for automotive and industrial applications, and for ground-referenced applications such as forward and flyback regulators

For FREE samples, datasheets, and more information, visit

www.national.com/pf/LM/LM5022.html

Driving LEDs: To Cap or Not to Cap

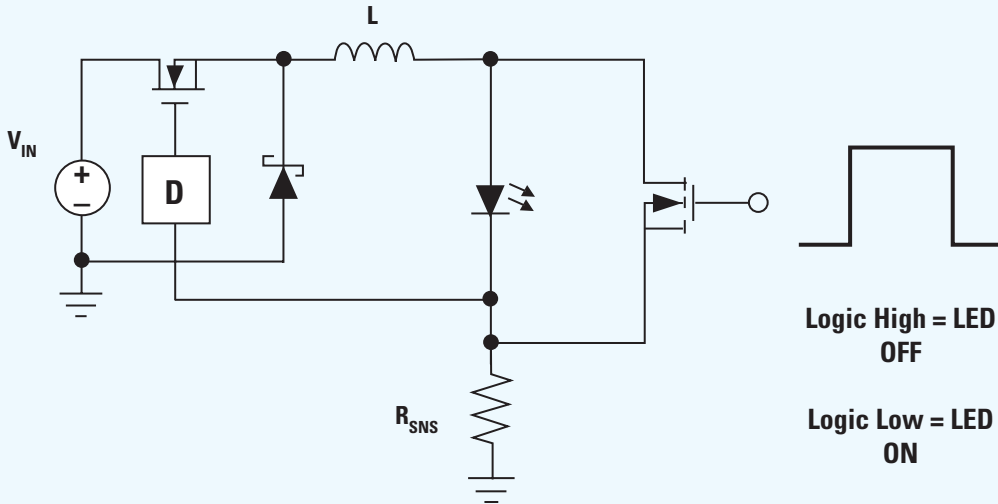

Figure 2. Dimming with a Parallel N-FET

Using an Output Capacitor Reduces Size and Cost

Some amount of output capacitance can be useful as an AC current filter. Applications such as retrofitting of incandescent and halogen lights often require that the LED and driver be placed in a small space formerly occupied by a light bulb. Invariably the inductor is the largest, most expensive component after the LEDs themselves. For the sake of efficiency (especially important in cramped quarters), the designer generally chooses the lowest switching frequency that allows the solution (mostly the inductor) to fit. Allowing a large ripple current in the inductor and filtering the LED current results in a smaller, less expensive solution. For example, to drive a single white LED ($V_F \approx 3.5V$) at 1A with a ripple current Δi_F of $\pm 5\%$ from an input of 12V at 500 kHz would require a 50 μH inductor with a current rating of 1.1A. A typical ferrite core device that fits this application might be 10 mm square and 4.5 mm in height. In contrast, if the inductor ripple current is allowed to increase to $\pm 30\%$ (typical for a low-current voltage

regulator) then the inductance required is less than 10 μH , and an inductor measuring 6.0 mm square and only 2.8 mm in height size can be used. The output capacitance required is calculated based on the dynamic resistance, r_D , of the LED, the sense resistance, R_{SNS} , and the impedance of the capacitor at the switching frequency, using the following expressions:

$$C_o = \frac{1}{2\pi \times f_{sw} \times (ESR + Z_c)}, \quad Z_c = \frac{\Delta i_F}{\Delta i_L - \Delta i_F} \times r_D$$

Typical values for output capacitors range from 0.1 μF to 10 μF , a perfect fit for ceramic capacitors. In many applications, the addition of an output capacitor reduces both the size and the cost of the total solution.

Output Capacitor Placement

For buck regulators that use PWM-based control, such as Voltage Mode (VM) and Current Mode (CM) the output capacitor should be connected from the regulator output to system ground,

Industry's Smallest, Fully Integrated Flash LED Driver

High-Power LED Driver Optimized for Driving Single- and Multiple-Die Flash LED Technologies in Handheld Applications

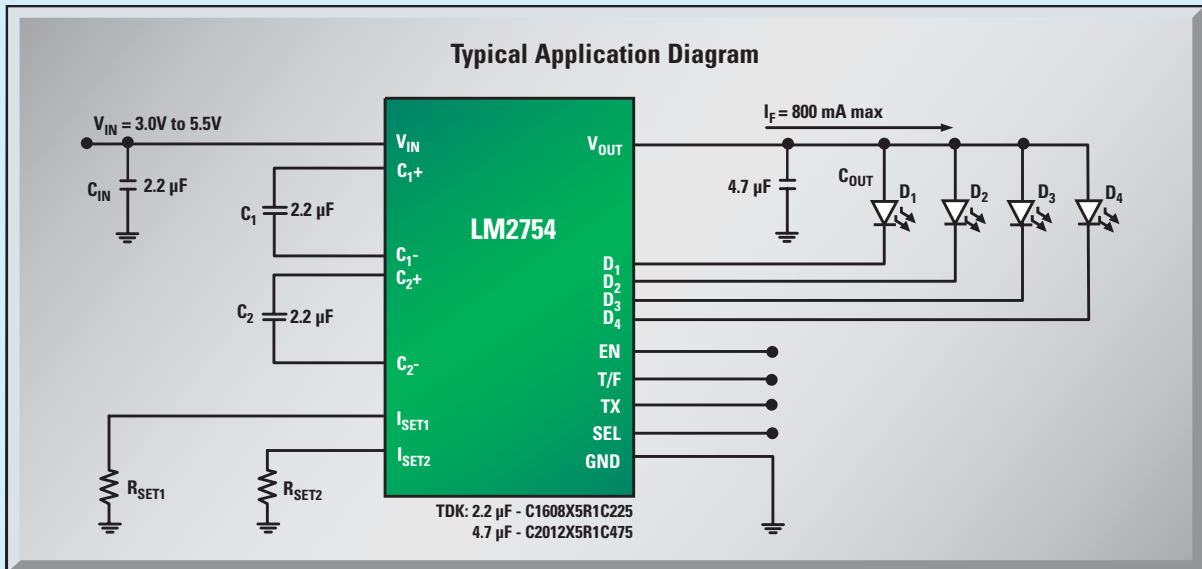

LM2754 Features

- Total solution size without LED < 28 mm²
- Time-out circuit limit flash duration to 1s, protects LED from over-heating
- No inductor required
- True shutdown output disconnect
- <1 μ A shutdown current
- TX input ensures synchronization with RF power amplifier pulse
- Ability to disable one current sink via the SEL pin to accommodate 3-LED flash modules
- Internal soft-start limits inrush current
- Available in LLP-24 (4 mm x 4 mm x 0.8 mm) packaging

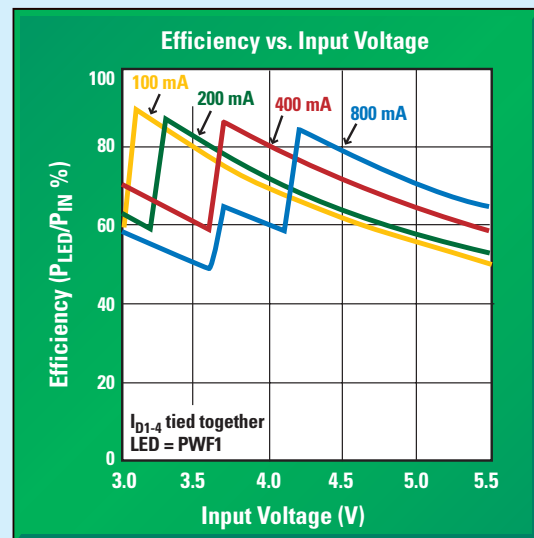

Ideal for camera flashes for mobile phones and flashes for digital still cameras

For **FREE** samples, datasheets and more go to
www.national.com/pf/LM/LM2754.html

Driving LEDs: To Cap or Not to Cap

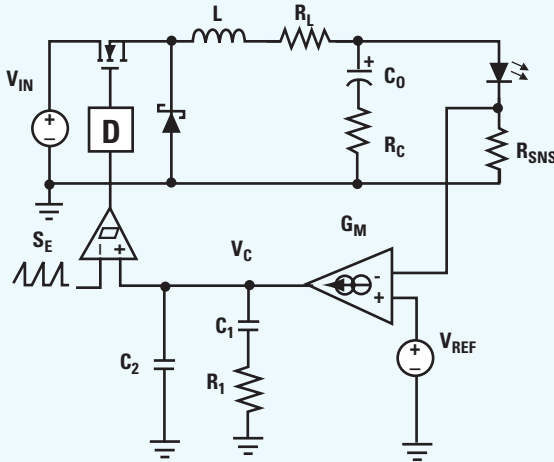

Figure 3a: PWM Regulator

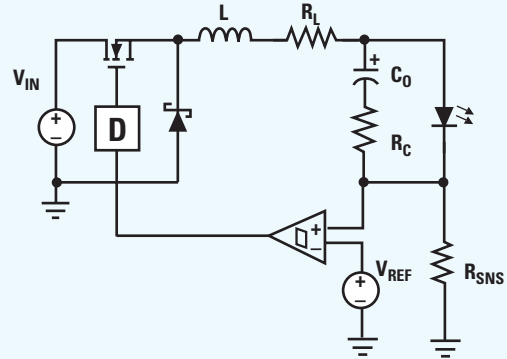

Figure 3b: Comparator-based Regulator

identical to a normal buck regulator. (Figure 3a) This way, the control-to-output transfer function of the system can be analyzed with the same equations used when designing a voltage regulator. When using comparator-based control, such as hysteretic or Constant on-Time (COT), the output capacitor should be placed in parallel with the LED array. (Figure 3b) In hysteretic voltage regulator circuits, this technique is often used to increase the percentage of in-phase voltage ripple at the feedback node. For the current regulator, it forces both the ripple current through C_O and the forward current through the LEDs to sum at the input to the switching comparator. The voltage waveform across R_{SNS} is therefore in-phase with the switching node waveform, and the result is predictable operation with high noise rejection. The combination of low output capacitance and high inductor current ripple actually makes hysteretic and COT current regulators more reliable and easier to design than voltage regulators.

Conclusion

The high brightness, high power LED represents the biggest change in lighting design since the introduction of fluorescent bulbs. Using LEDs requires a fundamental change in the complexity of electronics used for lighting systems. Currently a large portion of LED lighting design is retrofitting of incandescent, halogen, and fluorescent installations. Such systems rarely include sophisticated dimming control, and place a high value on small size. These are the applications where an output capacitor is a welcome addition to the driver circuit.

In the future, the higher cost of LEDs for general lighting will be balanced by new levels of control over brightness, tone, and color. Lighting in homes and businesses will require fast PWM dimming, requiring current drivers to minimize or eliminate their output capacitance. These systems will draw upon experience from today's fast-dimming applications which have already shed the output capacitor to provide the best response time. ■

Power Design Tools



WEBENCH® Online Design Environment

Our design and prototyping environment simplifies and expedites the entire design process.

1. Choose a part
2. Create a design
3. Analyze a power supply design
 - Perform electrical simulation
 - Simulate thermal behavior
4. Build it
 - Receive your custom prototype kit 24 hours later

webench.national.com

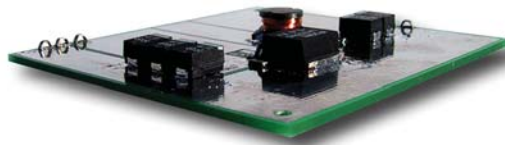
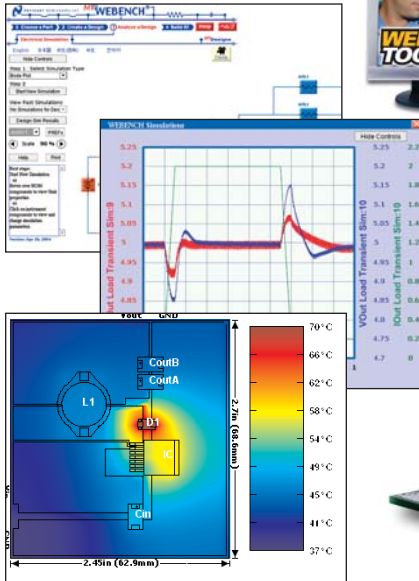

Reference Designs

National's power reference design library provides a comprehensive library of practical reference designs to speed system design and time-to-market.

www.national.com/refdesigns



National Semiconductor
2900 Semiconductor Drive
Santa Clara, CA 95051
1 800 272 9959

Mailing address:
PO Box 58090
Santa Clara, CA 95052

Visit our website at:
www.national.com

For more information, send email to:
new.feedback@nsc.com

Don't miss a single issue!

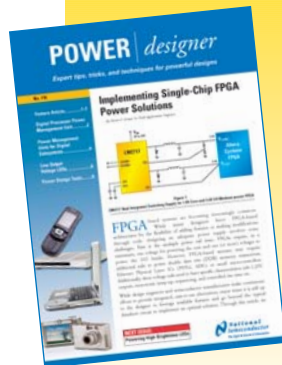

Subscribe now to receive email alerts when new issues of Power Designer are available:

power.national.com/designer

Read our Signal Path Designer® online today at:

signalpath.national.com/designer

