

Matching Driver to LED

LED Design includes understanding the electrical drive portion of lighting solutions

January 2008

Chris Richardson, National Semiconductor

Introduction

LED lighting offers many potential benefits over incandescent, halogen, fluorescent and gas/arc lamps, and lighting designers are eager to take advantage of those benefits. While the market for retrofitting is immense, it is the ground-up design of solid-state lighting that truly exhilarates the lighting design community. To succeed in an LED lamp design three major pieces must be carefully managed. These pieces are the electrical drive, thermal management, and the optics. The lighting designer who can successfully balance all three can enjoy the benefits of solid state lighting: long life, high electrical efficiency, high luminous efficacy and pure color (or tightly controlled color temperature for white LEDs).

Taking Stock of the LEDs Themselves

A single LED die intended for solid state illumination is generally made from one of two semiconductor materials. Red, orange and amber LEDs are made almost exclusively from InAlGaP. Green and blue LEDs are made almost exclusively with InGaN. White LEDs are generally made from a blue LED with a conversion phosphor, and from an electrical drive standpoint are identical to blue LEDs. Like standard silicon PN junction diodes, LEDs conduct current when they are forward biased. Unlike standard PN junction diodes, an LED in forward bias emits light. Two features set LEDs apart from other lighting sources: first, LEDs are driven by current, and second, the forward voltage across an LED is low and is DC. The typical forward voltage, V_F , ranges from 2V to 3V for InAlGaP LEDs, and from 3V to 4V for InGaN, but the luminous flux of an LED is proportional to the forward current, I_F .

The first piece of the electrical drive design is fixing the drive current, and the second piece is determining the voltage range of each LED. Careful review of the manufacturer's datasheet will yield a recommended drive current, along with typical, minimum and maximum values for V_F , dominant wavelength, and luminous flux at the specified current. Graphs of typical V_F vs I_F are shown in *Figure 1*, and it is important to note that current is the independent quantity, reflecting the fact that current control is the key part of an LED driver.

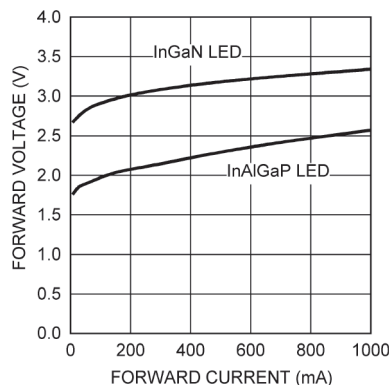

Figure 1. V_F vs I_F for a Red InAlGaP and a White InGaN LED

Choices in Array Design Affects Performance

Even with the leaps and bounds that have taken place in power LEDs in recent years, a single device is rarely enough to provide all the light needed for general illumination. A flagship 1W white LED (typical CCT 6500K) from leading manufacturers may yield 100 lumens. Those 100 lumens are distributed over a relatively narrow angle in comparison to a typical 60W incandescent light bulb. With a typical luminous efficacy of 15 lm/W, the light bulb yields 900 total lumens, with light spread almost equally in all directions. More than one LED will be needed if the goal is to light a space formerly occupied by the light bulb. Placing the LEDs in series guarantees that the same current flows through each device, and is the best way to ensure uniform light from each individual device.

In general, as many LEDs are placed in series as possible, and then further series chains are added until the total light output reaches the desired level. The number of LEDs that can be placed in series depends upon several factors, but is primarily dominated by the input voltage, electrical codes and safety standards, and the LED driver itself (*Figures 2,3,4*).

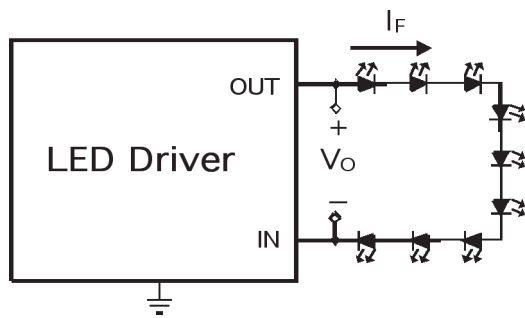

Figure 2. Nine LEDs in Single Series Chain

Arranging the LEDs as shown in *Figure 2* has the advantages of using a single LED driver and a guarantee of equal current flowing through each LED. As a drawback, this configuration leads to the highest output voltage, which translates into larger, more expensive circuit components and more requirements for safety. In addition, if any of the LEDs fail and create an open circuit, then the entire lamp goes dark.

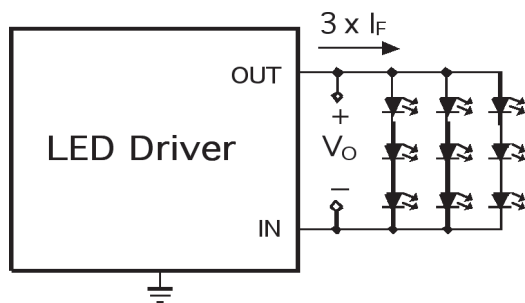

Figure 3. Nine LEDs in a 3x3 Series-Parallel Array

Arranging the LEDs as shown in *Figure 3* has the advantage of using a lower output voltage and reducing the hazard of electric shock. If one LED fails open circuit, the other two branches continue to operate, however this can be both beneficial and harmful. On one hand, a failure of one LED will not disable the entire lamp. On the other hand the LED driver, being a current source, will now force more current ($1.5 \times I_F$) into the remaining branches. This can cause the LEDs to overheat, reducing their lifetime. A second disadvantage of the series-parallel array is that the LEDs will not share the drive current equally unless their V_F is matched. This requires them to be binned by the manufacturer and increases their cost. Finally, even with V_F binning the negative temperature coefficient of V_F in LEDs can cause an imbalance in the current from branch to branch if the lamp design does not provide equal heatsinking for each LED.

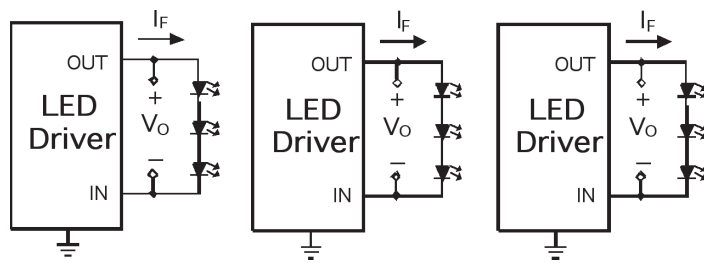

Figure 4. Nine LEDs Driven by Three Drivers of Three LEDs Each

A conservative method is to use three independent drivers with three LEDs each (nine total LEDs driven) which provides the greatest system reliability, but at the highest cost, and using the most space (*Figure 4*). Using separate drivers keeps the output voltage low, does not require V_F binning, and the lamp can still maintain some light output even if two LEDs in two different strings fail. If the LED drivers are switching regulators then the cost and footprint of three drivers in addition to the passives that surround them can be excessive.

Input Voltage

Under no circumstances can a single LED be connected directly to 110VAC or 220VAC. The result is spectacular but brief (and hazardous!) There are DC sources, such as batteries, solar cells, and fuel cells, but for general illumination AC line voltage is the most common input. A circuit is needed that is capable of taking in a relatively high AC voltage and sending out a DC current at a relatively low voltage. Electrical codes vary from country to country, in wet vs dry locations, and in sealed vs open fixtures, however in general few applications are permitted more than 60VDC at the output.

Using LEDs for general illumination is a science still in its infancy, and while standards and codes remain vague or in a state of flux the safe choice is to create an intermediate DC bus voltage using existing offline power supplies that provide galvanic isolation, power factor correction, and already meet the applicable safety codes. The output voltages are most commonly 12V, 24V, and 48V, and in the past 3-4 years various DC-DC converters ICs have been released that take in those common DC voltages and output constant current to a string of LEDs.

How to Pick a Driver IC

Several manufacturers offer complete AC input, DC current output driver modules that meet isolation and PFC requirements, however by necessity such products are limited in the number and type of LEDs that they can drive. DC-DC converters are a natural fit for driving LEDs precisely because their outputs are constant, matching the needs of the LEDs. To achieve the flexibility needed for a variety of LEDs arrayed in a variety of configurations, the solid state lighting designer must be aware

of the DC-DC converter ICs that are available, and how to select the most appropriate part for their application.

To begin, the IC must be able to handle the input voltage that is selected, and it must be able to output the required current over a range of output voltage that is often quite wide. For a system with a number of series connected LEDs 'n', the total output voltage required will be:

$$V_0 = n \times V_F + V_{SNS}$$

In this equation ' V_{SNS} ' represents the voltage dropped across a series current sensing element, usually a resistor.

For systems where V_{IN-MIN} exceeds V_{O-MAX} the buck regulator can be used. Buck regulators are the preferred choice for switching converter-based LED drivers because of their simplicity, low parts count, ease of adaptation to constant current output and wide selection of control ICs.

For systems where V_{O-MIN} exceeds V_{IN-MAX} a boost regulator should be used. Boost regulators do not adapt as easily to LED driving, but they use a single inductor and two power switches like the buck regulator, enjoy high efficiency, and are second only to the buck regulator in terms of control IC selection.

Finally, if the range of V_{IN} and V_0 overlap, a buck-boost regulator will be required. This type of regulator should be the last resort for the electrical drive design, however the combination of input voltage range and tolerance combined with the tolerance of the V_F of LEDs due to process and temperature often forces the lighting designer to make this difficult choice. Buck-boost regulators tend to use more parts, be less efficient, and are more difficult to design than either the buck or the boost regulator. Furthermore, while the buck regulator and the boost regulator each use one basic topology, buck-boost regulators are available using the single inductor inverting topology, SEPIC topology, Cuk topology, and flyback (coupled inductor) topology, among others.

The Features that Make the Driver

Almost any DC-DC converter IC with an adjustable output voltage can be converted into a current regulator for driving LEDs, but this solution is not ideal. A dedicated high-power LED driver should have several features that distinguish it from other DC-DC converters. The key specification is the ability to sense and control output current both accurately and efficiently. The current sense voltage, V_{SNS} , must be low enough to minimize power dissipation in the

current sense resistor, regardless of whether that resistor is internal or external to the IC. V_{SNS} must not be so low as to compromise the signal-to-noise ratio, however. Of particular value are those ICs that allow the user to adjust V_{SNS} in proportion to a control voltage. This allows the user the flexibility to make their own tradeoffs in efficiency vs SNR, and also functions as a linear current adjust.

Dimming of the light output of LEDs is done with pulse width modulation in order to maintain a consistent color or color temperature of the light. Above a certain frequency (generally 200 Hz) the human eye cannot distinguish the individual pulses, and by adjusting the pulse width while keeping the 'ON' state LED current at a certain level the average level of light perceived varies accordingly. LED driver ICs should accept logic-level PWM signals and be able to act as high fidelity bi-level amplifiers – applying pulses to the LEDs at a controlled current that match the logic signal. In order to keep the output current pulses true to the PWM signal, the propagation delay must be minimized and the slew rates of rising and falling LED current maximized. This eliminates the enable/shutdown pin of most standard power supply control ICs, which normally incur large delays in an effort to minimize shutdown current, and purposefully limit slew rates for the purposes of tracking, soft-start and sequencing.

Buck converter based LED drivers should be able to operate without output capacitors, as this converts their outputs to high impedance, and makes them the closest match to the ideal current source with infinite impedance. Without output capacitance the output voltage can slew very quickly, which is essential for fast PWM dimming. A buck converter without output capacitance can be coupled with a parallel dimming FET, shown in *Figure 5*. This dimming method reduces propagation delays and slew rates by at least an order of magnitude. This is possible because keeping the inductor current continuous eliminates the biggest system delay. As a drawback, some power is wasted while the LEDs are off, however the output voltage drops to equal V_{SNS} , minimizing the power that is lost. It is important to note that the buck converter is the only switching regulator topology that offers parallel FET dimming.

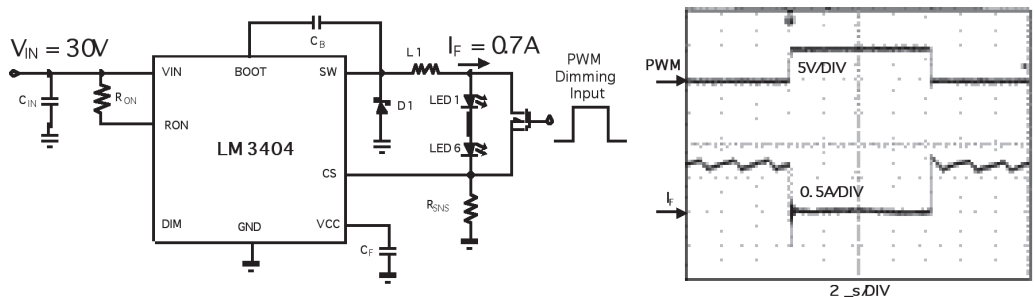

Figure 5. Buck LED Driver with Parallel FET Dimming

LED drivers are often exposed to ambient temperatures that are extreme even for a power supply IC. The high cost and physical space requirements of heatsinks, the reliability concern associated with fans and the generally cramped quarters that the LEDs and driver share translate into a harsh thermal environment. Operating ratings that extend to at least 125°C along with high power packaging are needed. Power LEDs are usually mounted on a metal-core PCB (MCPCB) that consists of an aluminum substrate with a dielectric and copper layer for electrical connections.

The best (lowest) thermal resistance for the drive electronics is achieved when a driver in a thermally enhanced package is also mounted on the MCPCB. Examples of thermally enhanced packages include leadless leadframe packages with a thermal tab in the center, as well as footprint compatible versions of leaded packages such as SOIC-8 and TSSOP-14 that have a thermal slug underneath. The high cost of aluminum substrates rarely permits the luxury of mounting the drive electronics on MCPCB, so in the majority of applications the LED driver must combat high ambient temperature and the reduced thermal performance of standard FR4 PCB.

When LEDs are directly driven by a switching regulator, the failure mechanism that causes the most concern is an output open circuit. Some LED drivers offer a current limit, but when output current is controlled in steady state, the biggest fear is that one of the LEDs will fail open circuit. This is the most common failure mechanism for LEDs, and it has the effect of disconnecting the feedback path. Regardless of control type, the result will be an unbounded increase in output voltage.

Buck regulators have a moderate safety issue, as V_O can only rise as high as V_{IN} . Boost and buck-boost LED drivers must take precautions because their outputs will rise until one or more circuit components break down.

Just as voltage regulators have reset, hiccup, or latch-offs when they encounter output short circuits, LED drivers, especially boost or buck-boost types should provide automatic protection in the case of output open circuits. When standard products are used to drive LEDs, a zener diode (Z1) can be used to keep the output voltage bounded, as shown in *Figure 6*. The zener breakdown voltage should be set above the maximum V_O of the regulator, and the reverse current is typically set to 1 mA to minimize power dissipation in case the fault condition lasts for an extended time.

Conclusion

The first generation of high power LED drivers, both modules and ICs, is now more than three years old. Leading manufacturers have completed their second generation of products based on the learnings of the first, and are designing future generations of high power LED drivers to tackle the new problems that have arisen as LEDs push into the field of general illumination. To complete a successful design both the lighting designers and the LED driver manufacturers (modules and ICs) will have to take a step across the void that often separates them. The IC makers must listen and produce products that solve current challenges, and the lighting designers must become more fluent in electronics. With these steps taken, high quality, high efficiency, long-lasting LED lighting will become a reality.

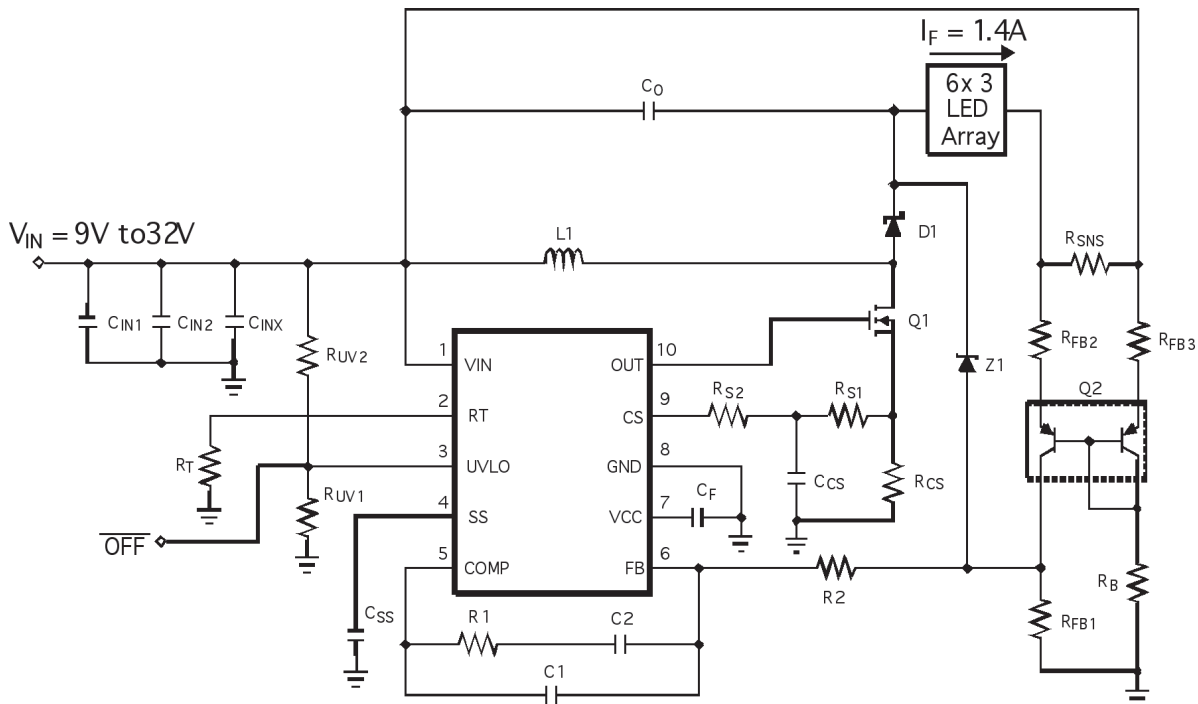

Figure 6. Buck-Boost LED Driver

Topology Selection Examples

1. Using a Buck Regulator

Consider a small LED lamp that will use a total of six white (InGaN) LEDs. The driving current will be $1A \pm 10\%$, a standard current for 3W LEDs. All six LEDs will be placed in series, and review of the LED datasheet yields the following forward voltage data:

$$V_{F-MIN} = 3.0V, V_{F-TYP} = 3.7V, V_{F-MAX} = 5.0V$$

The LEDs can be binned to reduce the range of V_F however this increases the cost, especially if the LEDs used are already binned for luminous flux and/or color temperature. If the entire V_F range will be used then output voltage can vary from 18V to 30V. This lamp will be sold worldwide, and must operate from a universal AC input voltage range of 85VAC to 265VAC. The decision is made to purchase a standard offline power supply that will deliver an intermediate bus voltage, V_{BUS} . Offline supplies with standard output voltages have the greatest selection and lowest cost, so the choices for V_{BUS} are 12V, 24V, or 48V, each with a tolerance of $\pm 5\%$. Using 48V is ideal because it will provide the most efficient, least expensive LED driving topology – the buck. What's more, the offline converter stage will be more efficient than the 12V or 24V options because the output current is lower and the conversion ratio is lower when stepping the AC voltage down to 48V. *Figure 7* shows a practical implementation of a buck LED driver.

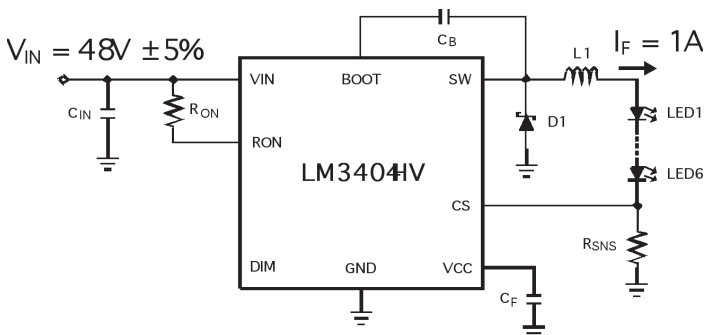

Figure 7. Buck LED Driver

2. Using a Boost Regulator

Boost regulators are more commonly found in portable, battery input applications. Both the inductive and the switched-capacitor type have found great success in powering small LEDs for backlighting displays, however this application is a high power portable lamp for applications such as bicycle headlamps or military/police flashlights. The light will be generated by three 1W white LEDs, driven at $350 mA \pm 10\%$. As with the previous example, the datasheet states the following forward voltage limits:

$$V_{F-MIN} = 3.0V, V_{F-TYP} = 3.7V, V_{F-MAX} = 5.0V$$

The input for the lamp will be three 1.5V AA cells, with an operating voltage of 1.5V per cell when fully charged down to 0.9V when fully discharged. All three batteries could be placed in parallel,

but this leaves very little voltage for the driver IC to work with. Instead, the three cells are placed in series. V_{IN} ranges from 2.7V to 4.5V, and V_{O-MIN} is 9V, making the inductive boost a perfect fit. An example circuit is shown in *Figure 8*.

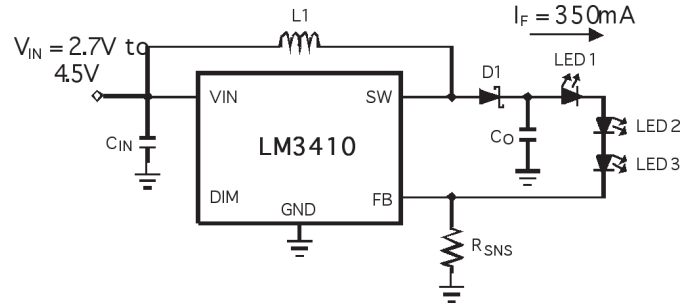

Figure 8. Boost LED Driver

3. Using a Buck-Boost Regulator

Automotive electrical systems present a particular challenge for LED drive electronics because of their wide voltage range, yet automotive was an early adopter of high power LEDs because of their reliability, longevity and optical efficiency. Tail lights, turn signals and interior lighting were quick to convert to solid state lighting, but forward lighting (low beams, high beams, fog lights, etc.) have proven more difficult because of the number of LEDs needed to achieve the luminous flux required. This problem is compounded by the high ambient temperature in an automotive environment, as all LEDs lose light output as their die temperature rises.

Besides the LED manufacturers themselves, several companies purchase bare dice and specialize in the packaging, producing multi-die LED modules to tackle the problem of getting lots of light (1000+ lumens) from a small area. One such product combines 18 dice in three parallel strings of six series-connected LEDs. Total drive current is 1A, and V_F varies from 18V to 24V. The standard automotive battery and alternator system operates over a range of 9V to 16V, but usually includes the 'double battery' test which typically requires that the system electronics function (or at least survive) at 28V for two minutes or longer. The 'load dump' surge (resulting from a disconnection of the battery when the alternator is running) can exceed 100V, but is often clamped to approximately 40V. This wide input voltage range forces the driver to buck and boost.

Single inductor buck-boosts such as the example circuit shown in *Figure 6* have the advantage of a lower parts count than the SEPIC, Cuk or four-switch buck-boosts. As a disadvantage, their outputs are controlled with respect to V_{IN} and this requires a floating, differential current sense to complete the control loop. This is accomplished with a low-cost dual PNP transistor (Q2) in *Figure 6*, but can be achieved with better accuracy and improved performance over temperature with IC current sense amplifiers. ■

For more information on LED Drivers, visit: national.com/LED